

SDAC User's Guide

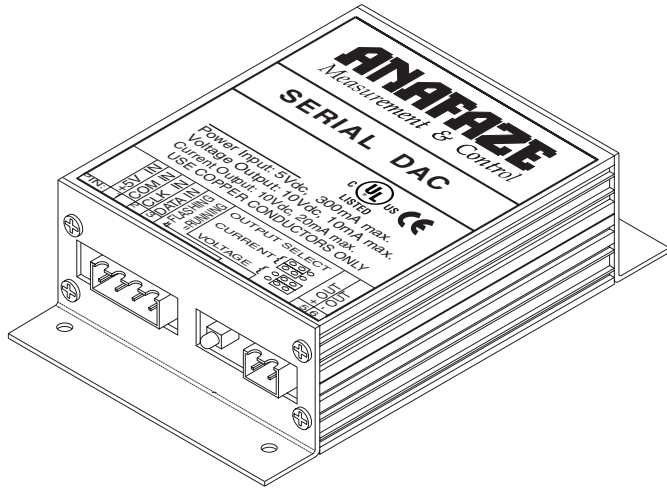

Watlow Controls
1241 Bundy Blvd., Winona, MN 55987

Customer Service
Phone: 1-800-414-4299
Fax: 1-800-445-8992

Technical Support
Phone: (507) 494-5656
Fax: (507) 452-4507

E-mail: wintechsupport@watlow.com

Introduction

The Serial Digital-to-Analog Converter (Serial DAC) is an optional module for Watlow Anafaze Controllers. It allows the controller to output precision analog voltages or currents. The Serial DAC is typically used for precision open-loop control, motor or belt speed control, or phase-angle fired control.

This manual contains installation instructions, configuration information, and specifications.

Features

- Electrically isolated
- 0.003% resolution and linearity; factory calibrated to 0.05% accuracy for voltage outputs and 0.5% accuracy for current outputs. The Serial DAC can also be recalibrated to 0.1% accuracy on current output.
- User-selectable voltage or current output.
- Controller setup menus allow zero- and full-scale value adjustments within the Serial DAC's 0 to 10V_{dc} (dc) and 0 to 20 mA_{dc} (dc) output ranges.

Installing the Serial DAC

You will need the following tools:

- Power drill with 4-mm (0.15-in) bits
- Screwdriver
- Four screws up to size #6 (up to 3.8 mm). Choose screws appropriate for your panel material.
- Wire strippers

To install the SDAC module:

1. Choose a wall or panel to install the Serial DAC. For best results choose a location near the controller and in an area free from dust, excessive heat and moisture and unauthorized personnel.
2. Drill four holes for screw mounting. *See Figure 1 on page 2* for mounting hole dimensions and placement.
3. Place the Serial DAC in its mounting location so that the screw holes in the Serial DAC line up with the holes you have drilled. Insert the screws in the holes and tighten.
4. Shut the system power off and wire the Serial DAC to the controller and final control element.

Warranty

The Serial DAC is warranted to be free of defects in material and workmanship for 36 months after delivery to the first purchaser for use, providing that the units have not been misapplied. Since Watlow has no control over their use, and sometimes misuse, we cannot guarantee against failure. Watlow's obligations hereunder, at Watlow's option, are limited to replacement, repair, or refund of purchase price, and parts which upon examination prove to be defective within the warranty period specified. This warranty does not apply to damage resulting from transportation, alteration, misuse, abuse, or improper fusing.

Part No. 0600-2185-2000 Rev. 4.0
December 2004

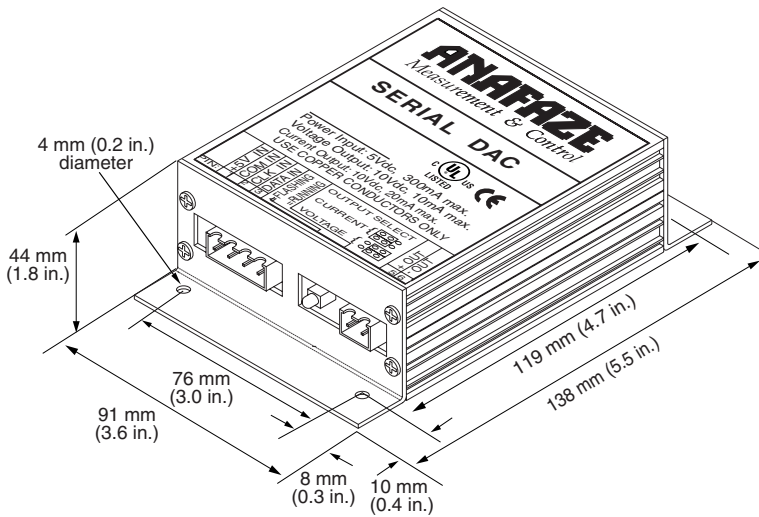

Figure 1. Serial DAC Dimensions

Wiring the Serial DAC

The Serial DAC provides a robust analog output signal. The module converts the proprietary Serial DAC signal from the controller's open collector output in conjunction with the clock signal to an analog current or voltage. See *Figure 2* for wiring a Serial DAC. The Serial DAC is user-configurable for voltage or current output. Refer to *Figure 3* for configuration information.

The Serial DAC optically isolates the controller's control output from the load. One Serial DAC may be powered by the 5V_{DC} (dc) supplied by a CLS200, MLS300 or CPC400 controller at its output terminal board. These controllers cannot provide sufficient current for more than one Serial DAC; use an external power supply.

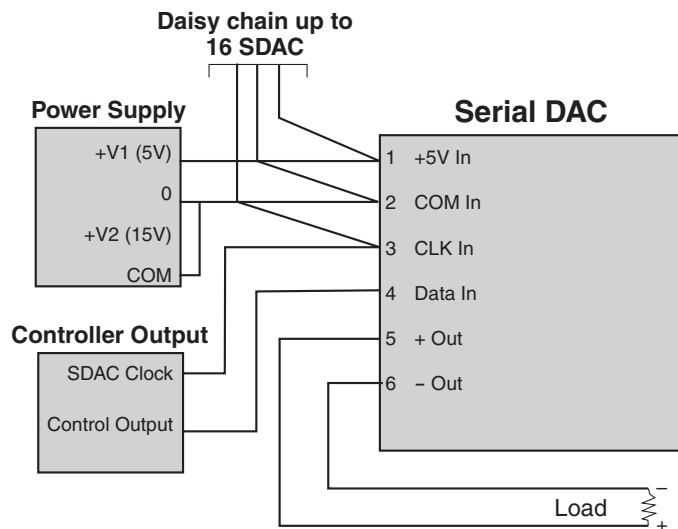

Figure 2. Single or Multiple Serial DACs with External Power

WARNINGS



WARNING

The SDAC module is for indoor use only. To reduce the risk of fire or electrical shock, install in a controlled environment relatively free of contaminants.



WARNING

Use a power supply with a Class 2 rating only.

NOTE

Tighten screw terminal connections to 0.5 to 0.6 Nm (4.5 to 5.4 inch-pound).

NOTE

Use copper conductors only.

Configuring Serial DAC Outputs

The Serial DAC's voltage and current output is jumper selectable. Refer to *Figure 3*. Configure the jumpers as indicated on the Serial DAC label.

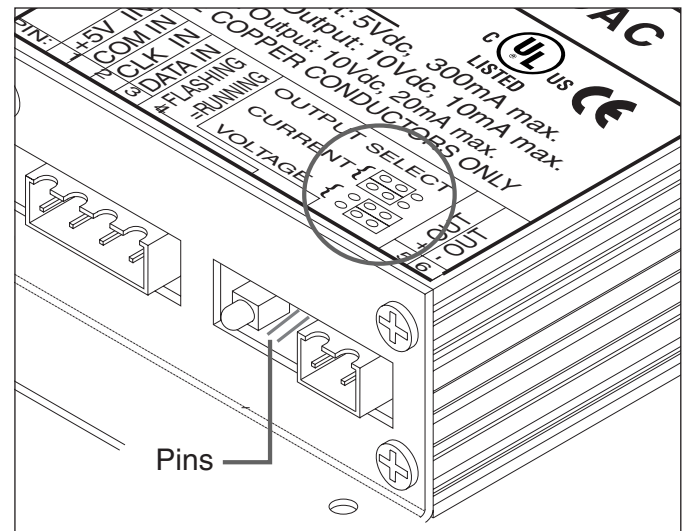

Figure 3. Voltage and Current Jumper Positions

Setup and Operation

Using the Serial DAC with a Controller

Complete the following steps to set up your Serial DAC:

1. Check the Output Select jumpers on the Serial DAC. Make sure that both jumpers are set for either voltage or current.
2. In the controller menus:
 - Set the output type to SDAC (Serial DAC).
 - Select the Serial DAC signal type: Voltage or Current.
 - Set the desired high and low output signal values.

The exact parameter names vary depending on the controller. See your controller manual.

Testing the Serial DAC

1. In the controller, select the loop to be tested.
2. Set the control output to manual mode.
3. Set a percent output level.
4. Use a volt or current meter to verify the output level of the Serial DAC.

Troubleshooting

The following section contains troubleshooting information for the Serial DAC.

Check the following first:

- Are the controller and Serial DAC wired and configured correctly?
- Are the inputs to the controller, such as thermocouples and RTDs, installed and working correctly?

Green Light on Serial DAC Does Not Light

Use a voltmeter to check:

- 5V power is present at the Serial DAC.
- Power is present at the controller.

Also, check data and clock line wiring, and make sure that the controller's output type is set to Serial DAC for that loop.

Erratic and Incorrect Output Level

Check for reversed data and clock lines.

Output Level Incorrect, or No Output

- Check current and voltage jumper settings on the Serial DAC.
- Check the controller's voltage or current low and high output level settings.
- Make sure the Serial DAC data input is wired to the correct loop output.

Calibration Procedure

The standard Serial DAC is calibrated for precision voltage output. To recalibrate your Serial DAC to output currents with 0.1% accuracy, follow these steps:

NOTE

This procedure should be performed only by a technician familiar with calibrating electronic equipment. The voltage or current meter used should have the appropriate precision and be properly calibrated.

1. Remove the two plug-in terminals.
2. Unscrew either end panel.
3. Gently slide the card out.
4. Reinstall the plug-in terminals:
5. Recalibrate the circuit:
 - a. Connect the voltage or current meter to the output.
 - b. Connect the Serial DAC to the controller.
 - c. Set the controller's output to Manual Mode, 0% Output.
 - d. Adjust the control labeled "zero" to get the desired output — typically 4.000 mA for current outputs.
 - e. Set the controller's output to 100% output. Adjust the control labeled "span" to get the desired full scale output (typically 20.000 mA).
 - f. Repeat *steps c through f* until you have achieved the desired accuracy.
6. Remove the plug-in terminal blocks from the Serial DAC.
7. Gently slide the card back into the appropriate casing slot.
8. Screw on the end panel.
9. Replace the plug-in terminal.

Specifications

Watlow Anafaze offers a Serial DAC for precision open-loop control. The Serial DAC is jumper selectable for a voltage or current output. Multiple Serial DAC modules can be used with one controller.

The Serial DAC carries the CE mark.

Table 1. Serial DAC Environmental Specifications

Storage Temperature	-20 to 60°C (-4 to 140°F)
Operating Temperature	0 to 50°C (32 to 122°F)
Humidity	10 to 95%, non-condensing

Table 2. Physical Specifications

Weight	0.34 kg	0.76 lb
Length	138 mm	5.5 in
Width	91 mm	3.6 in
Height	44 mm	1.8 in

Table 3. Agency Approvals / Compliance

CE Directive	Electromagnetic Compatibility (EMC) directive 89/336/EEC
UL® and C-UL®	UL916, Standard for Energy Management Equipment, File E177240

Inputs

The Serial DAC requires a proprietary serial data signal and the clock signal from the controller. The Serial DAC also requires a 5V_{DC} power input.

Table 4. Screw Terminals

Wire Gauge	24 to 12 AWG
Screw Terminal Torque	0.5 to 0.6 Nm (4.5 to 5.4 inch-pound)

Table 5. Serial DAC Inputs

Parameter	Description
Data	4 mA maximum to DC COM Open collector or HC CMOS logic levels
Clock	0.5 mA maximum to DC COM Open collector or HC CMOS logic levels

Table 6. Power Requirements

Parameter	Description
Voltage	4.75 to 5.25V _{DC} @ 300 mA maximum

Analog Outputs

Table 7. Output Specifications

Parameter	Description
Absolute Maximum Common Mode Voltage	Measured between output pins and controller common: 1,000V
Resolution	15 bits (plus polarity bit for voltage outputs) (0.305 mV for 10V output range) (0.00061 mA for 20 mA output range)
Accuracy (calibrated for voltage output)	For voltage output: +/- 0.005V (0.05% at full scale) For current output: +/- 0.1 mA (0.5% at full scale)
Temperature coefficient	440 ppm/°C typical
Isolation Breakdown Voltage	1000V between input power and signals
Current	0 to 20 mA with 10V minimum compliance (500 ohm load)
Voltage	0 to 10V _{DC} with 10 mA source capability
Output Response Time	1 ms typical
Update Rate	Once per controller A/D cycle nominal. Twice per second maximum for 60 Hz clock rate. Output changes are step changes due to the fast time constant. All Serial DAC loop outputs are updated at the same time.