

DAC User's Guide



Watlow Controls
1241 Bundy Blvd., Winona, MN 55987

Customer Service
Phone: 1-800-414-4299
Fax: 1-800-445-8992

Technical Support
Phone: (507) 494-5656
Fax: (507) 452-4507

E-mail: wintechsupport@watlow.com

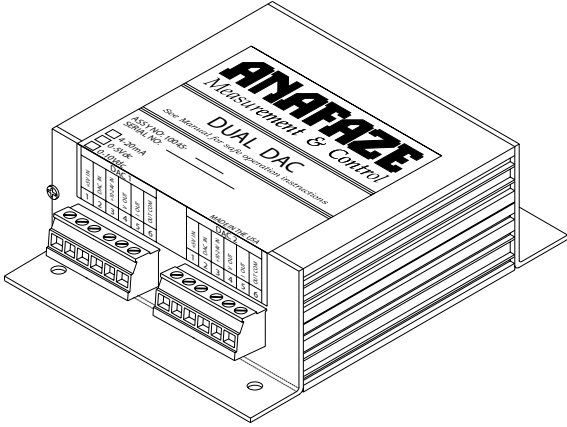

Introduction

The Digital to Analog Converter (DAC) is an optional module for Watlow Anafaze controllers. It is used to convert the controller's Distributed Zero Crossing (DZC) output signal to an analog process control signal. Each DAC supports 4 to 20 mA, 0 to 5V and 0 to 10V output signals. This manual contains installation instructions, configuration information, and specifications.

Installing the DAC

You will need the following tools:

- Power drill with 0.15 inch bit
- Screwdriver
- Four screws up to #6 size. Choose screws appropriate for your panel material.
- Wire strippers

To install the DAC module:

- Choose a wall or panel to install the DAC.
- Drill four holes for mounting screws. Refer to Figure 1 for mounting hole dimensions and placement.
- Place the DAC in its mounting location so that the holes in the DAC line up with the holes you have drilled. Insert the screws in the holes and tighten.
- Shut the system power off and wire the DAC to the controller and final control element. *Figure 2* shows the wiring for current. *Figure 3* shows the wiring for voltage.

Ordering Information

DAC -

DAC Type

- 1 Dual digital to analog converter module (converts two DZC control outputs to two 0 to 5V $\overline{=}$ (dc) analog outputs). Separate power supply required.
- 2 Dual digital to analog converter module, (converts two DZC control outputs to two 0 to 10V $\overline{=}$ (dc) analog outputs). Separate power supply required.
- 3 Dual digital to analog converter module, (converts two DZC control outputs to two 4 to 20 mA $\overline{=}$ (dc) analog outputs). Separate power supply required.

Power Supply

- A None
- B 120V \sim (ac) 60Hz wall mount power supply adapter (15V $\overline{=}$ [dc] @ 800 mA, powers up to 8 dual DAC modules).
- C 120/240V \sim (ac) 50/60Hz panel mount power supply adapter (5V $\overline{=}$ [dc] @ 4 A, 15V $\overline{=}$ [dc] @ 1.2 A, powers up to 12 dual DAC modules).

Warranty

The DAC is warranted to be free of defects in material and workmanship for 36 months after delivery to the first purchaser for use, providing that the units have not been misapplied. Since Watlow has no control over their use, and sometimes misuse, we cannot guarantee against failure. Watlow's obligations hereunder, at Watlow's option, are limited to replacement, repair, or refund of purchase price, and parts which upon examination prove to be defective within the warranty period specified. This warranty does not apply to damage resulting from transportation, alteration, misuse, abuse, or improper fusing.

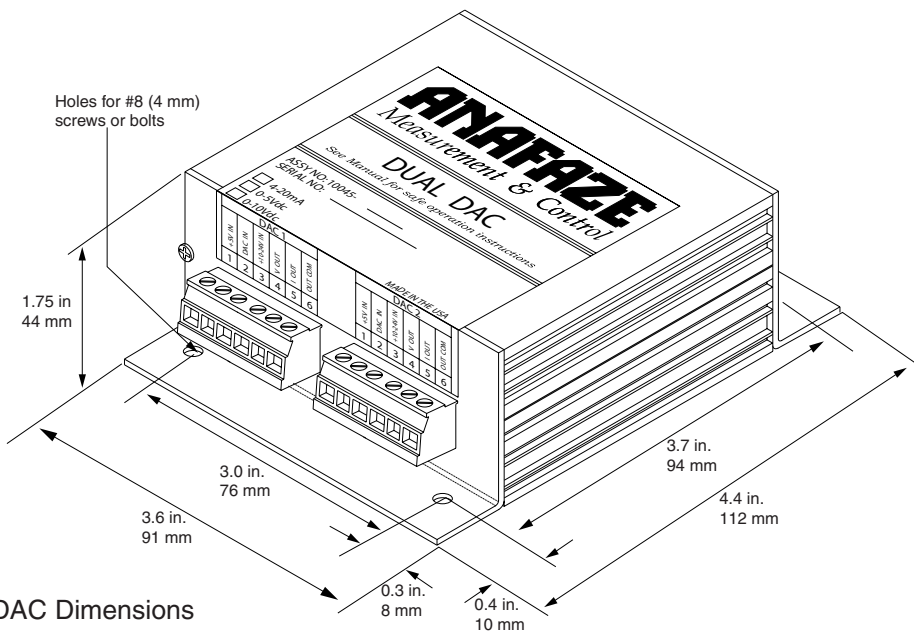

Figure 1. DAC Dimensions

Wiring the DAC

A DAC module includes two identical circuits. Each can convert a controller's DZC or burst fire signal to an analog voltage or current signal. Devices that are driven by analog signals are often sources of electrical noise. Without the proper isolation noise may interfere with the controller's operation. To isolate the measurement and control circuits from such noise, power DAC modules with a dc power supply that is isolated from the controller's power supply.

Several DAC modules may be powered by one power supply. Consult *Specifications* for the DAC's power requirements.

Operation

Before operating your DAC:

- Make sure the jumpers have been set for the desired output signal type. See *Configuring DAC Outputs*.
- Select Distributed Zero Crossing (DZC) as the output type for the corresponding loop or channel.

To test the DAC:

1. Select the loop to be tested.
2. Set the control output to manual mode.
3. Set a percent output level.
4. Use a volt or current meter to verify the output level.

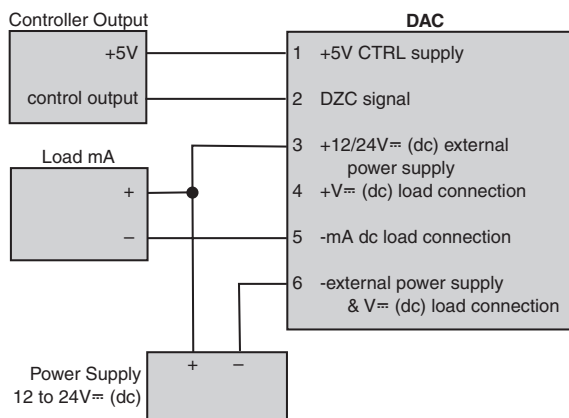

Figure 2. DAC with Current Output

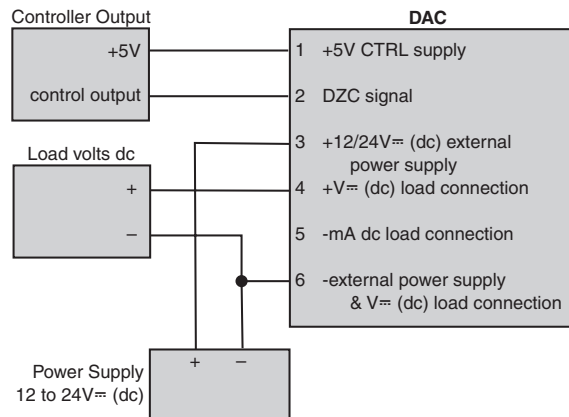

Figure 3. DAC with Voltage Output

Configuring DAC Outputs

The DAC module ships with both outputs configured for the signal type and span ordered. The module contains two independent circuits (DAC1 and DAC2). These circuits can be configured for different output types by changing the jumper settings for one or both outputs. The odd numbered jumpers determine the signal from DAC1; the even numbered jumpers determine the output from DAC2.

To change the output ranges:

1. Power down the system (if DAC is already installed and wired).
2. Ensure the DAC1 and DAC2 terminal blocks or associated wires are labeled so that you will know which terminal block connects to which side of the board if the module is already installed and wired.
3. Unplug the two terminal blocks.
4. Depending on the installation, you may need to unmount the DAC module before proceeding. Remove the four screws from the end plate on the opposite side of the module from the terminal blocks.
5. If necessary, remove the two mounting screws holding the loosened end plate in place.
6. Slide the board out of the housing.
7. Set the jumpers for the two outputs as desired. See Tables 1A and 1B.
8. Replace the board such that the connectors extend through the opposite end plate. The board fits in the third slot from the bottom.
9. Reconnect the two terminal blocks to the DAC1 and DAC2 connectors.
10. Replace the end plate, end plate screws and, if necessary, mounting screws.
11. Check the wire connections to the DAC1 and DAC2 terminal blocks.
12. If necessary, change the wiring connections to the correct configuration for the new output type.
13. Restore system power if the system was powered down in Step 1.

WARNINGS



WARNING

The DAC module is for indoor use only. To reduce the risk of fire or electrical shock, install in a controlled environment relatively free of contaminants.



WARNING

Use a power supply with a Class 2 rating only.

NOTE

Tighten screw terminal connections to 0.5 to 0.6 Nm (4.5 to 5.4 inch-pounds).

NOTE

Use copper conductors only.

NOTE

Use the DAC only with appropriately sized loads. See the *Specifications* section for minimum and maximum allowable impedances.



CAUTION

To avoid the RF interference problems that frequently accompany motor speed control circuits, do not use power from the controller. Use a separate power supply.

Table 1A. DAC1 Jumper Settings

Output Signal	Jumper Settings						
	1	3	5	7	9	11	13
0 to 5V ^{DC} (dc)	B	A	A	O	B	A	O
0 to 10V ^{DC} (dc)	B	A	A	O	B	O	O
4 to 20 mA	O	A	B	A	A	O	A

Table 1B. DAC2 Jumper Settings

Output Signal	Jumper Settings						
	2	4	6	8	10	12	14
0 to 5V ^{DC} (dc)	B	A	A	O	B	A	O
0 to 10V ^{DC} (dc)	B	A	A	O	B	O	O
4 to 20 mA	O	A	B	A	A	O	A

Legend:

- A:** Load jumper in the “A” position, or load jumper if header has only two pins.
- B:** Load jumper in the “B” position.
- O:** Open; do not load jumper.

Specifications

This section specifies the input requirements and performance standards for the DAC module.

Table 2. DAC Environmental Specifications

Storage Temperature	-20 to 60° C
Operating Temperature	0 to 50° C
Humidity	10 to 95% non-condensing

Table 3. Physical Specifications

Weight	0.42 pound	0.19 kg
Length	4.4 inches	112 mm
Width	3.6 inches	91 mm
Height	1.8 inches	44 mm

Table 6. Output Specifications

Configuration	4 to 20 mA	0 to 5V	0 to 10V	Units
Gain Accuracy	±6	±6	±6	percent
Output Offset	±0.75	±0.75	±0.75	percent of full scale range
Ripple	1.6	1.6	1.6	percent of full scale range
Response Time	2	2	2	seconds
Max Current Output	20	10	10	mA dc
Load Resistance Using 12V Power Supply	250 max.	500 min.	1,000 min.	ohms
Load Resistance Using 24V Power Supply	850 max.	500 min.	1,000 min.	ohms

Inputs

The DAC accepts an open-collector signal from the controllers and the power from an external power supply.

Table 4. DAC Power Requirements

Parameter	Description
Voltage	12 to 24V _{DC}
Current (2 Outputs)	100 mA @ 15V _{DC}

Table 5. Screw Terminal

Wire Gauge	Screw Terminal Torque
24 to 12 AWG	0.5 to 0.6 Nm (4.5 to 5.4 inch-pounds)